

BALE OPENER

- designed with a clear mission in mind



- a strong solution for the environment



BALE OPENER

Opening of bales made easy

The ReTec bale-opener was designed with a clear mission in mind: To offer a simple, powerful and reliable method to automatically and completely open any type of bales at a high capacity and with low operating cost.

Simple, powerful, reliable

The engineering principle behind the bale-opener is logically simple. The bale is led forward on a beltconveyor towards the large rotating ripper drum. With its 1300mm diameter and powered by 45kW e-motor, the ripper drum delivers a huge torque. Therefore even very high density bales and heavier material is opened

effortlessly. Only industry leading component manufacturers are used (SEW or Nordgear for motors and transmissions, SKF bearings, IFM controls).

Capacity

The capacity matches the speed at which it is normally possible to feed the machine with 1 forklift. This is approximately maximum 1 bale per 45 second, or approximately 80 tph of RDF.

Range

The bale-opener is in-different to the shape of the bale, and how it is wrapped and/or tied. The bale-opener is suited to open a wide variety of

material: RDF, SRF, Paper, PET and mixed plastics to name a few.

Quality

Following the range of material the bale-openers throughput is adjustable via the in-feed speed and the opening gap. The bale-opener can run in "max mode" where capacity is highest priority (RDF for Waste-to-Energy plants), or it can run in "soft mode" where less throughput is needed and where the material should not be damaged (PET, plastics etc.).

Automatic

The in-feed speed is automatically regulated by the actual power





consumption, and in case of excess loads an auto reverse function is programmed.

Health and safety

The bale-opener is safely operated only by the forklift driver that feeds the machine. There is no need for people being on the floor, or any physical contact to the bales with knife, cutters etc. The machine is certified according to CE 2006/42/EC.

Low operating cost

The main motor is 45kW. The average power consumption significantly less. Opening 80 tons of RDF with less than 45 kW is unmatched in the industry.

The bale-opener does not have any knives, but uses “plates”. Therefore the wear costs are significantly lower than a shredder or similar equipment. In total the machine opex is extremely low - around 0,10 € per ton.

Service

Standard of the shelf components are used wherever possible. ReTec has its own dedicated service department. Therefore we can offer high quality service on short notice.

Your partner

ReTec Miljø ApS develops, constructs and manufactures special machines for the waste and recycling industry. We offer practical solutions



to our customer’s needs, helping them increase profitability in waste management and recycling. All our solutions are developed and manufactured in-house at our facility in Haderslev, Denmark.



Technical specification

Input material	Any kind of wrapping and tying (steel) <ul style="list-style-type: none"> • Solid recovered fuel (SRF) • Refuse derived fuel (RDF) • PET • Mixed plastics • Straw bales • Paper bales 		
Input size	Round bales	Diameter	1200 mm
		Width	1200 mm
	Rectangular bales	Length	1750 mm
		Height	1300 mm
Physical dimensions		Width	1400 mm
		Length	7110 mm
		Width	2863 mm
		Height	3594 mm
Capacity	Up to 80 tph (RDF). Pending the size, conformity and density of the bales.		
Rotor		Diameter	1300 mm
		Width	1490 mm
		Material	Steel
Transmission power	Rotor 45 kW, Belt 2,2 kW		
	3-fase+PE 400 V AC 160 A fuse		
Surface treatment	Sandblasted and painted RAL 5010, blue		
Controls	IFM or Siemens PLC and frequency control		
Options	Data modem interconnect to PLC		
	Remote control start/stop		
	Semi-mobile version		
System solution	We can offer complete installations with Fe removal of wires and/or mechanical size screening		

RBO 1513R-W2R

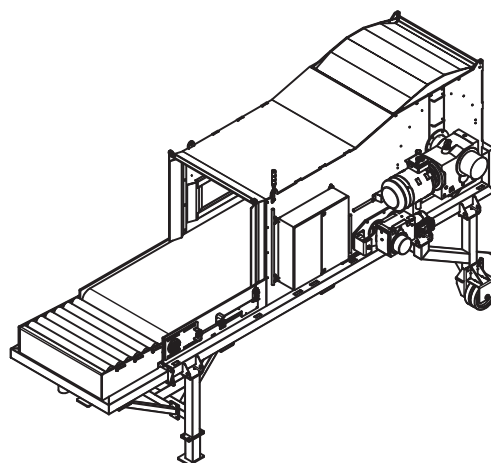
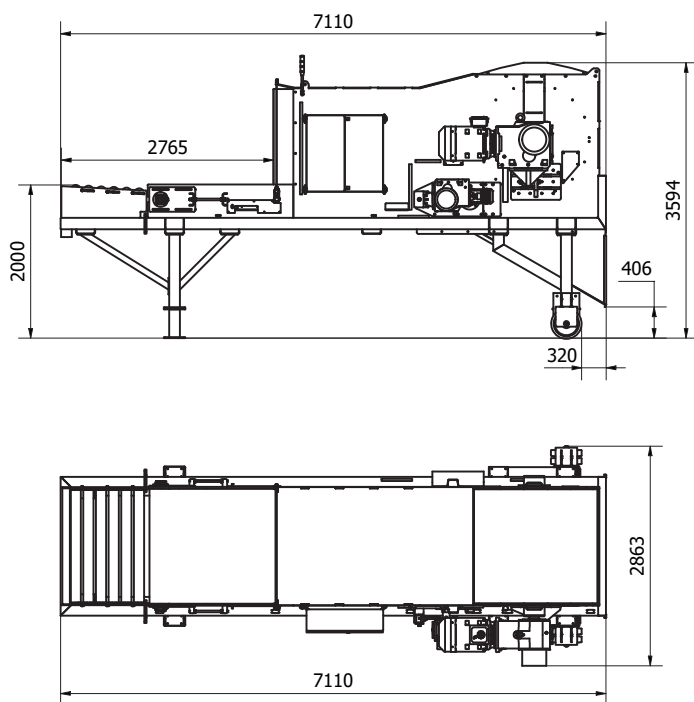

ReTec Miljö AB
Kolonivägen 63
SE-371 54 Karlskrona

Tel.: +46 (0) 70 337 20 10

info@retecmiljo.se
www.retecmiljo.se

ReTec utvecklar, konstruerar och tillverkar specialmaskiner för avfall och återvinningsindustrin. Vi erbjuder praktiska lösningar enligt kundens behov, som hjälper dem att öka lönsamheten i sin verksamhet.