



shredding technology

The reliable brand!

# LRK CLASS

1-shaft shredder for shredding of recyclable materials



LRK700 | LRK1000 | LRK1400

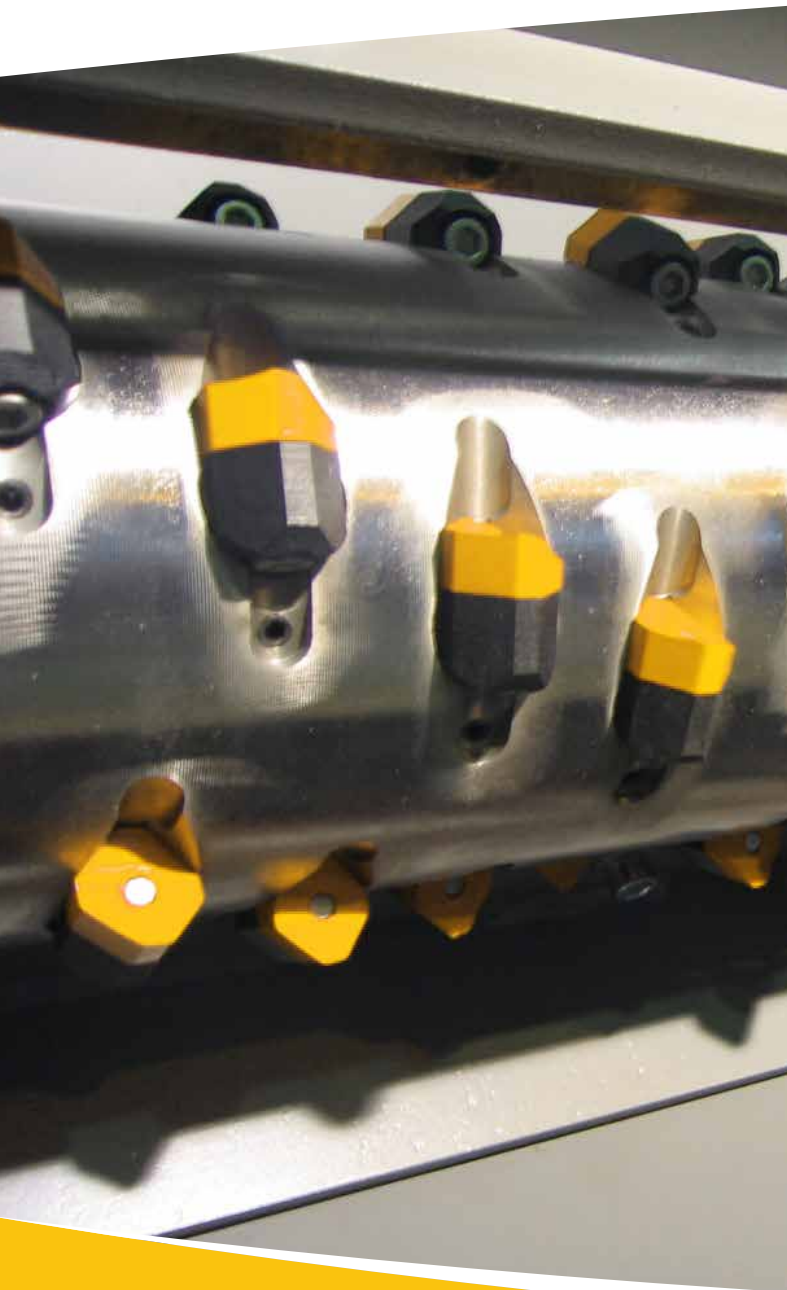

## POWERFUL AND EFFICIENT

The reliable and rugged LRK class shredders are popular with companies in the plastics processing industry for volume reduction and in-house recycling.

Like all UNTHA shredders, these machines can stand alone or be integrated into comprehensive systems. High throughput, outstanding availability and consistent particle sizing ensure an efficient and profitable operation.

## AREAS OF APPLICATION

- Dashboards
- Interior auto trim
- Spring mattresses
- Plastic film
- Green waste
- Rubber waste
- Cardboard packaging
- Cardboard tubes
- Plastic packaging
- Plastic drums
- Paper
- Paper rejects
- Plastic bottles
- Production waste
- Punching scrap
- Bumpers
- Carpets and rugs
- Tetra pack
- Textiles
- Workshop waste
- Packaging material
- etc.



## UNTHA RESEARCH & DEVELOPMENT CENTRE

In 2000, UNTHA opened a modern research and development centre where trials and tests with customers' specific materials are simulated under practical conditions.

The focus is always on the customer and on fulfilling each task in the best possible manner. The technology centre enables us to gain important experience and data so we can offer the ideal shredding solution for any given task.

Take this opportunity and make an appointment at our test and demonstration centre!

Tel +43 6244 7016 0

# QUALITY FEATURES

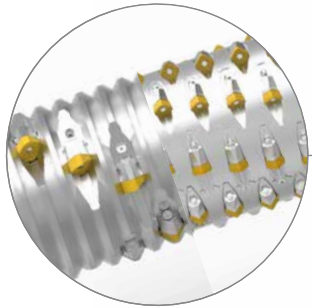

## Effective cutting system

The special rotors (smooth or profiled) have a large diameter and are equipped with bolted cutter holders.

The adjustable main and secondary cutting bar as well as the cutters may be reversed up to 4 times.

## Robust machine body

The compact construction facilitates a space-saving set-up and smooth integration in the overall plant. A low filling level ensures maximum flexibility when it comes to loading. The large filling volume increases the process safety and reduces the risk of bridge formations.



## Exchangeable perforated screens

Depending on the granule size, perforated screens are available in a range of diameters. Replacing or cleaning the screens is easy and time efficient.

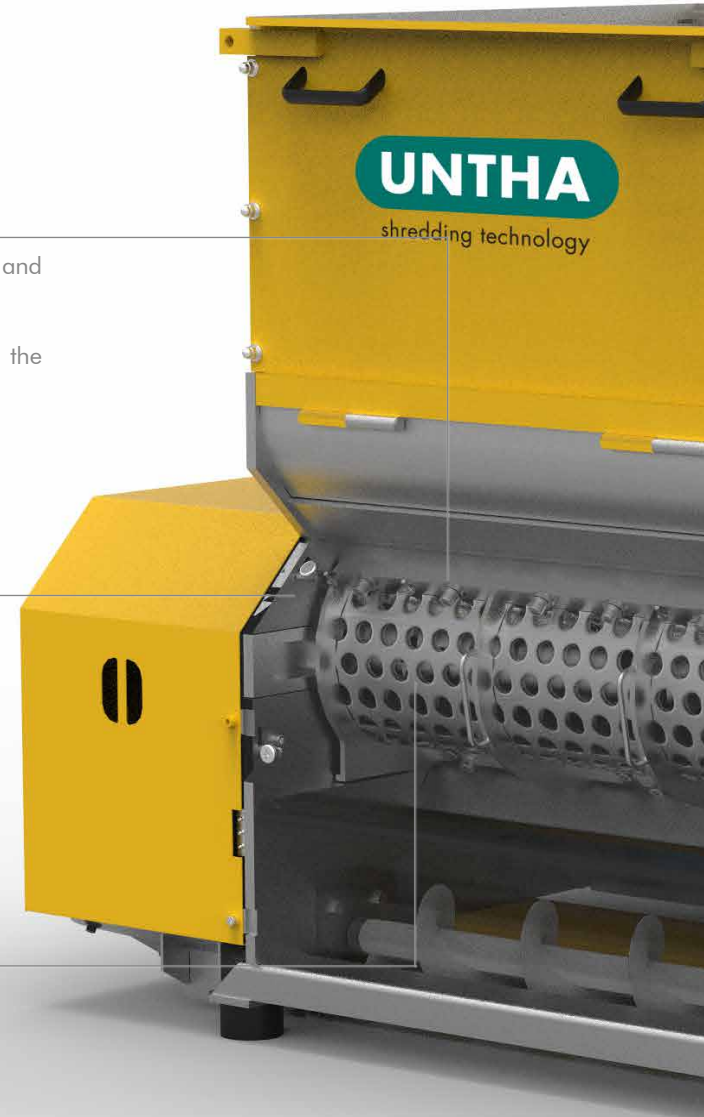

Symbolic image LRK1400.



### Maintenance-free pusher system

The powerful feeder and the cutting system ensure high throughput rates. The low-wear feeder guide provides for a long service life and low maintenance costs.



### Highly user- and maintenance-friendly

The easy-to-use control unit comes with three different programme settings, facilitating the efficient processing of different materials.

The service flap provides speedy access to the cutting chamber of the shredder, facilitating safe and efficient maintenance for maximum uptime.

### High-performance power train

The high-performance power train ensures a high rotor torque. An elastomer damper absorbs shocks and ensures the quiet running of the machine.





## YOUR CUSTOMISED MACHINE: EXTRAS

- **Flexible controller upgrades:** Facilitates customer-specific control system adaptations and enhancements.
- **Special attachment hoppers:** For optimal adjustment to the input material and feeding method.
- **Rotor wear protection (hard surfacing):** Significantly increases rotor availability with abrasive materials.
- **Automatic central lubrication system:** All important lubrication points are supplied continuously with lubricant and hence are less prone to wear.
- **Rotor cooler:** Ensures the reliable shredding of materials with a particularly low melting point.
- **Hold-down device:** Ensures the efficient shredding of bulky and light materials.
- **Discharge screw:** For easy and efficient discharge.
- **45° machine frame:** Provides a larger feed opening and increased hopper volume.
- **UNTHA Carefree Packages (gold, silver, bronze):** Ensure that machines are technically sound and ready for use at all times.
- **UNTHA Lifetime Support:** Guarantees maximum availability throughout the lifetime of the machine.

# LARK CLASS

## 1-shaft shredding system

SPECIFICATIONS		LRK700	LRK1000	LRK1400
Drive power	kW	18.5	22/30/44	30/44
Hydraulic power	kW	1.5	1.5	1.5
Ø Rotor	mm	300	300	300
Rotor speed	rpm	98	98	98
Number of cutters	pcs.	19 - 38	27 - 81	38 - 114
Feed opening	mm	700 x 1,065	1,000 x 1,050	1,400 x 1,050
Required suction speed	m/s	28	28	28
Weight	kg	1,800	3,000 - 3,400	3,500 - 3,800
Ø Screen	mm	15 - 40	15 - 40	15 - 40

	LRK700	LRK1000	LRK1400
B (mm)	1,310	1,863/2,010*	2,259/2,406*
T (mm)	1,710	1,645	1,645
H (mm)	1,630	1,704	1,704

Dimensions in mm.  
\*) Two-sided drive

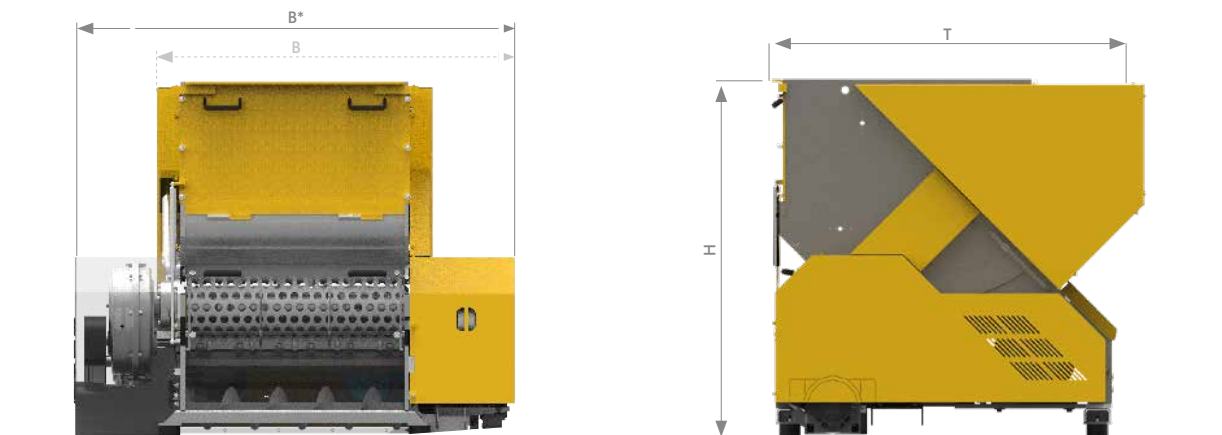

**40 years of expertise.**  
**More than 9,000 shredders in daily operation!**



shredding technology

The reliable brand!



**UNTHA shredding technology**

Kellau 141  
A-5431 Kuchl / Salzburg, Austria  
Tel +43 6244 7016 0  
Fax +43 6244 7016 1  
info@untha.com  
www.untha.com

Authorised partner of UNTHA



**ReTec Miljø ApS**  
Fjordagervej 38  
DK-6100 Haderslev  
Tel: +45 7456 8106  
www.retec.dk

**ReTec Miljö AB**  
Kolonivägen 65  
SE-371 54 Karlskrona  
Tel: +46 (0) 479 130 30  
www.retecmiljo.se

